



WINSFEED

WINCUT

EXPANSION OF TRIANGULAR
BLADES AND BLOCKS

**NEW TRIANGULAR BLADES AND BLOCKS
FOR PARTING AND DEEP GROOVING
WITH INTERNAL HIGH-PRESSURE COOLANT**

- *Switching hand types minus turret change*
- *Rigid clamping for excellent durability and repeatability*
- *User-friendly and rigid insert clamping system*
- *Improved chip evacuation*
- *With CoolBurst high pressure coolant system*

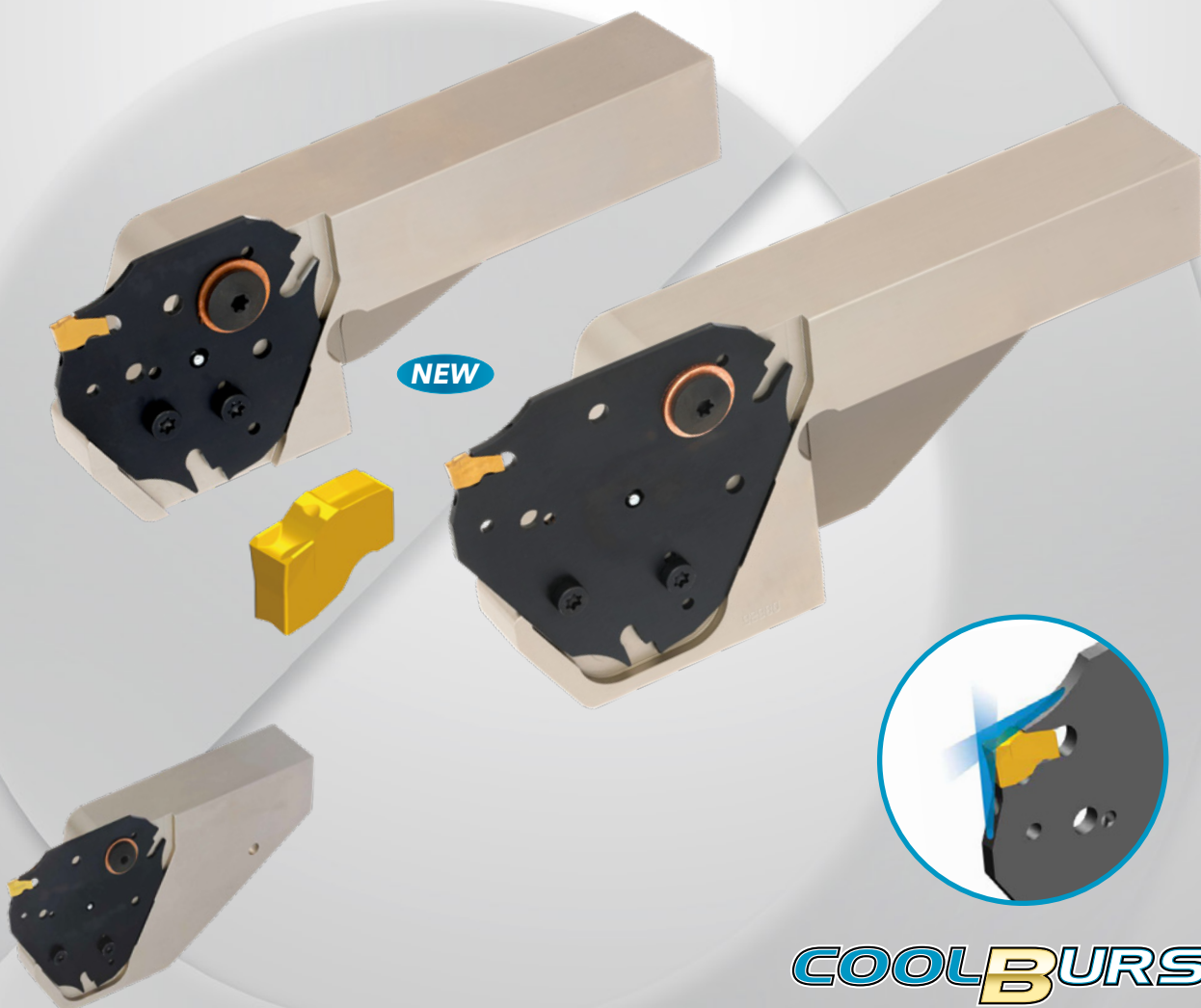

Product Overview

Ingersoll has launched new triangular blades and blocks to the **WinCut** line for parting and deep grooving using internal high-pressure coolant.

The **WinCut** line, which includes blades with three insert pockets and dedicated blocks, enables very stable machining in parting and deep grooving applications. In either high feed or interrupted cutting conditions, **WinCut** ensures an excellent surface finish with minimal vibration. Reinforced blocks, designed to support the three insert pocket blades, firmly seat the blade on two sides (the drophead and the turret). The blades include internal through-coolant channels directed to the insert's cutting edge, significantly increasing productivity and tool life.



Technical Features & Advantages

- Economical 3 insert pocket blade:
 - Direct lubrication to the cutting zone from the blade's top and bottom coolant channels
 - Internal through-coolant channels for improved tool life in both parting and deep grooving applications
 - Excellent chip evacuation ensures stable machining and excellent surface finish
 - Maximum productivity in high-speed, high feed machining conditions
 - User-friendly insert clamping system
- High rigidity triangular blades and dedicated blocks:
 - At least 3 times better rigidity comparing to conventional blade
- Triangular blades are compatible with **CutSFeed** and **TClamp** inserts
- Compatible with a wide variety of machines including multitasking and general CNC machines
- Maximum diameter Ø120 mm bars can be cut with 2 and 3 mm width inserts to reduce material costs

Rigidity: Triangular blade vs Conventional blade

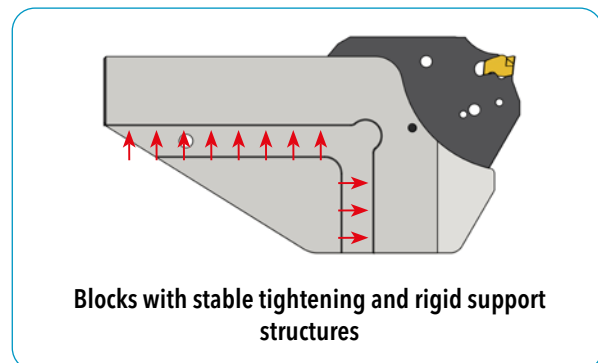
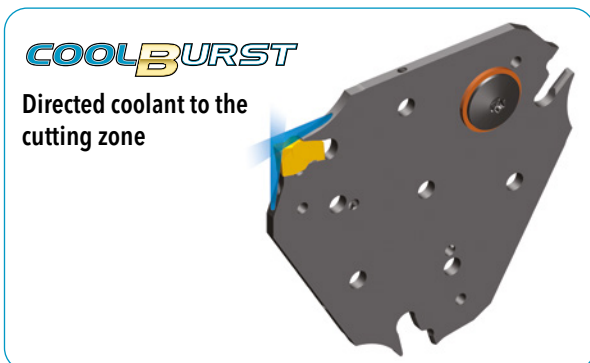
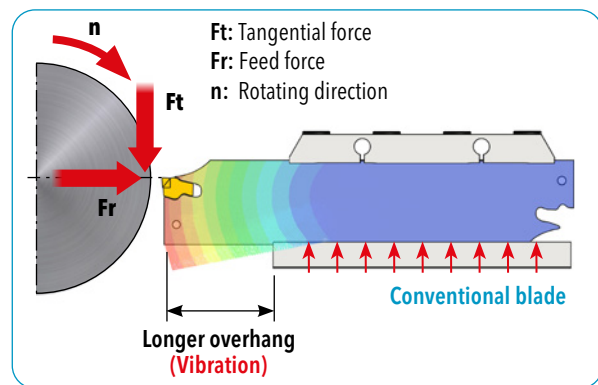
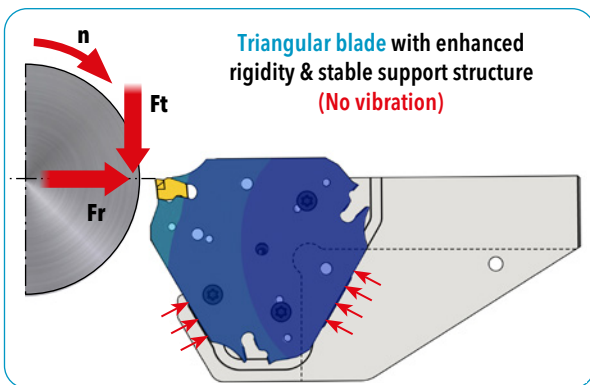

NEW WinCut blocks - Expansion

New blocks for triangular blades for machining next to spindle

For the current line of WinCut blocks' reinforced rib geometries limits the tool's hand type according to the turret's orientation, the line has been updated with new blocks capable of switching hand types minus the turret change, enabling machining on all applications.

With the ability to machine next to the spindle, the new block not only reduces material costs but also minimizes vibration during machining.

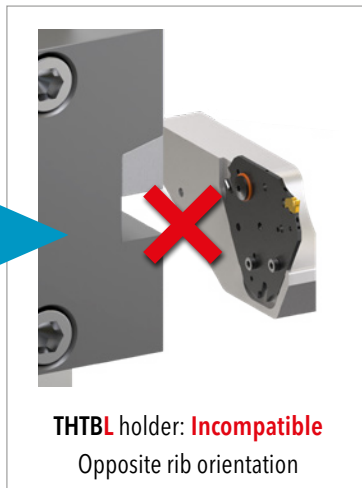
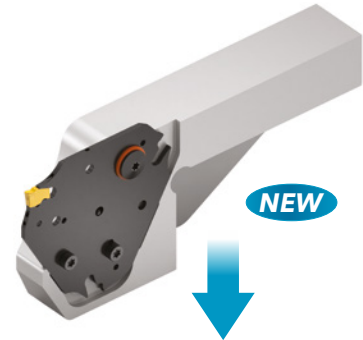

Pocket Orientation

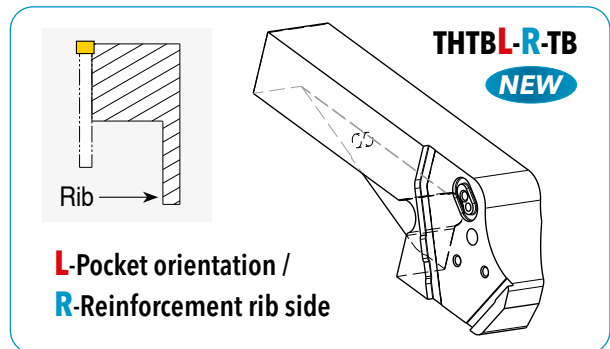
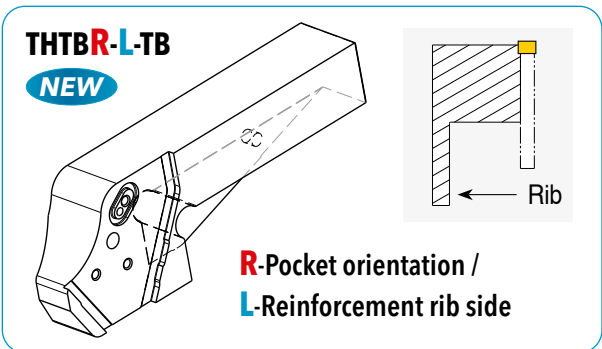
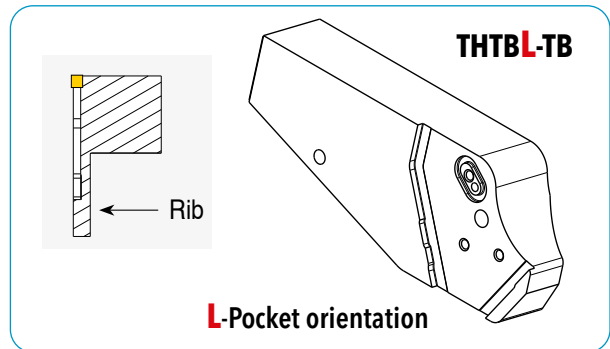
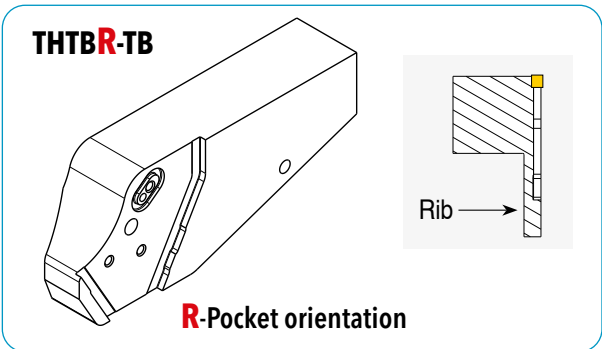

HOLDER FOR TRIANGULAR BLADES

NEW

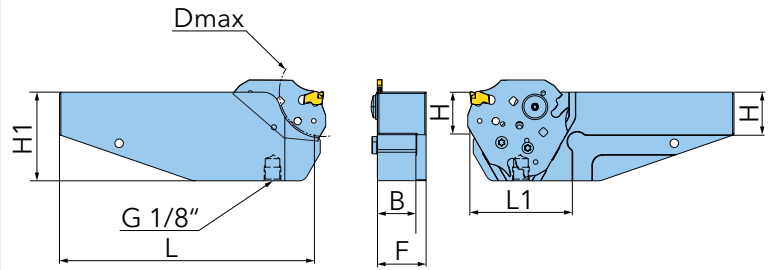

Designation	D max.	L	L1	H	H1	B	F	kg	IK	①	②	③	④
THTBR 25-L-D52-TB	52	155	60	25	27	22,5	28,5	1,460	✓	SH M4x0.7X10-TX	O-RING ID10x2	T 20	SIDETHRUSTPIN 3MM
THTBR 25-L-D82-TB	82	176,5	78	25	47	22,5	28,5	1,910	✓	SH M4x0.7X10-TX	O-RING ID10x2	T 20	SIDETHRUSTPIN 3MM
THTBR 25-L-D120-TB	120	211	113	25	70	22,5	28,5	2,680	✓	SH M4x0.7X10-TX	O-RING ID10x2	T 20	SIDETHRUSTPIN 3MM
THTBL 25-R-D52-TB	52	155	60	25	27	22,5	28,5	1,460	✓	SH M4x0.7X10-TX	O-RING ID10x2	T 20	SIDETHRUSTPIN 3MM
THTBL 25-R-D82-TB	82	176,5	78	25	47	22,5	28,5	1,910	✓	SH M4x0.7X10-TX	O-RING ID10x2	T 20	SIDETHRUSTPIN 3MM
THTBL 25-R-D120-TB	120	211	113	25	70	22,5	28,5	2,680	✓	SH M4x0.7X10-TX	O-RING ID10x2	T 20	SIDETHRUSTPIN 3MM

① = Clamp screw ② = O-ring ③ = Wrench ④ = Pin

HOLDER FOR TRIANGULAR BLADES

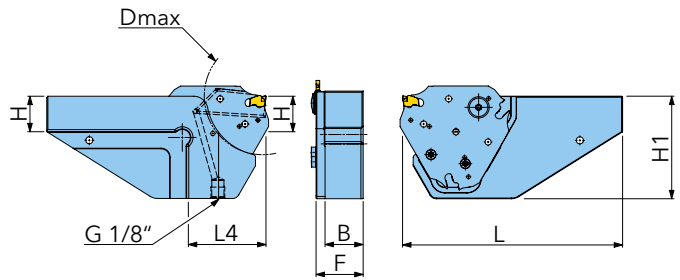

Designation	D max.	L	L4	H	H1	B	F	kg	IK	1	2	3
THTBL 20-D52-TB	52	125	40	20	52	17,5	23,5	0,66	✓	SH M4x0.7X10-TX	O-RING ID10x2	O-RING ID10x2
THTBL 25-D52-TB	52	135	40	25	52	22,5	28,5	0,85	✓	SH M4x0.7X10-TX	O-RING ID10x2	O-RING ID10x2
THTBL 20-D82-TB	82	140	51,5	20	72	17,5	23,5	0,80	✓	SH M4x0.7X10-TX	O-RING ID10x2	O-RING ID10x2
THTBL 25-D82-TB	82	150	51,5	25	72	22,5	28,5	1,10	✓	SH M4x0.7X10-TX	O-RING ID10x2	O-RING ID10x2
THTBL 25-D120-TB	120	165	67	25	95	22,5	28,5	1,29	✓	SH M4x0.7X10-TX	O-RING ID10x2	O-RING ID10x2
THTBL 32-D120-TB	120	165	67	32	95	29,0	35,0	1,79	✓	SH M4x0.7X10-TX	O-RING ID10x2	O-RING ID10x2
THTBR 20-D52-TB	52	125	40	20	52	17,5	23,5	0,66	✓	SH M4x0.7X10-TX	O-RING ID10x2	O-RING ID10x2
THTBR 25-D52-TB	52	135	40	25	52	22,5	28,5	0,85	✓	SH M4x0.7X10-TX	O-RING ID10x2	O-RING ID10x2
THTBR 20-D82-TB	82	140	51,5	20	72	17,5	23,5	0,80	✓	SH M4x0.7X10-TX	O-RING ID10x2	O-RING ID10x2
THTBR 25-D82-TB	82	150	51,5	25	72	22,5	28,5	1,10	✓	SH M4x0.7X10-TX	O-RING ID10x2	O-RING ID10x2
THTBR 25-D120-TB	120	165	67	25	95	22,5	28,5	1,29	✓	SH M4x0.7X10-TX	O-RING ID10x2	O-RING ID10x2
THTBR 32-D120-TB	120	165	67	32	95	29,0	35,0	1,79	✓	SH M4x0.7X10-TX	O-RING ID10x2	O-RING ID10x2

① = Clamp screw ② = O-ring ③ = Wrench

TRIANGULAR BLADES FOR PARTING AND DEEP GROOVING

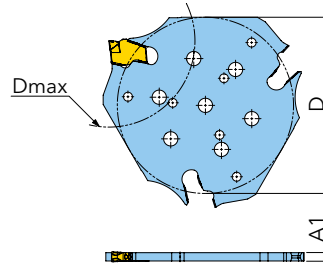

Designation	D	D max.	A1	insert-S	kg
SFTB D52-2	53,2	52	1,8	2	0,20
SFTB D52-3	53,2	52	2,5	3	0,20
SFTB D82-2	64,3	82	1,8	2	0,30
SFTB D82-3	64,3	82	2,5	3	0,30
SFTB D120-2	85,5	120	1,8	2	0,40
SFTB D120-3	85,5	120	2,5	3	0,40

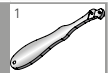

Extractor is not included.

1 = Extractor

TCLAMP^{ULTRA+} TGTB

TRIANGULAR BLADES FOR PARTING AND DEEP GROOVING

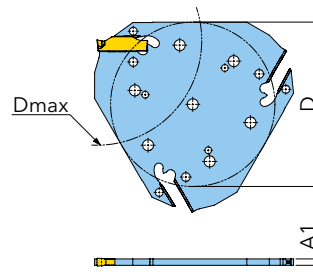

Designation	D	D max.	A1	Insert-S	kg
TGTB D52-2	53,2	52	1,8	2	0,20
TGTB D52-3	53,2	52	2,5	3	0,20
TGTB D82-2	64,3	82	1,8	2	0,30
TGTB D82-3	64,3	82	2,5	3	0,30



Extractor is not included.

1 = Extractor

TRIANGULAR BLADES FOR PARTING AND DEEP GROOVING WITH INTERNAL COOLING

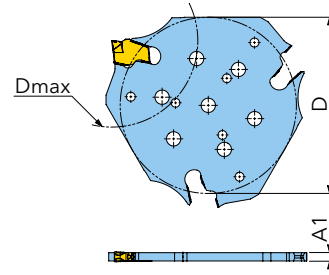

Designation	D	D max.	A1	Insert-S	kg	IK	1	2
SFTB D52-2-TB	53,2	52	1,8	2	0,029			
SFTB D52-3-TB	53,2	52	2,5	3	0,039		ETG 3-4	SGC 340-Q
SFTB D82-2-TB	64,3	82	1,8	2	0,050		ETG 3-4	SGC 340-Q
SFTB D82-3-TB	64,3	82	2,5	3	0,068		ETG 3-4	SGC 340-Q
SFTB D120-2-TB	85,5	120	1,8	2	0,103		ETG 3-4	SGC 340-Q
SFTB D120-3-TB	85,5	120	2,5	3	0,141		ETG 3-4	SGC 340-Q

Extractor is not included.

1 = Extractor 2 = Lock screw

TCLAMP^{ULTRA+} TGTB-TB

TRIANGULAR BLADES FOR PARTING AND DEEP GROOVING WITH INTERNAL COOLING

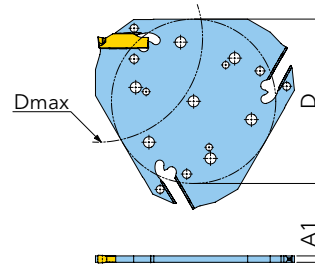

Designation	D	D max.	A1	Insert-S	kg	IK	1	2
TGTB D52-2-TB	53,2	52	1,8	2	0,028			
TGTB D52-3-TB	53,2	52	2,5	3	0,039		EDG 33B	SGC 340-Q
TGTB D82-2-TB	64,3	82	1,8	2	0,050		EDG 33B	SGC 340-Q
TGTB D82-3-TB	64,3	82	2,5	3	0,065		EDG 33B	SGC 340-Q

Extractor is not included.

1 = Extractor 2 = Lock screw

Ingersoll Cutting Tools

Marketing & Technology

Germany

Ingersoll Werkzeuge GmbH

Kalteiche-Ring 21-25

35708 Haiger, Germany

Phone: +49 2773 742-0

Email: info@ingersoll-imc.de

Internet: www.ingersoll-imc.de

France

Ingersoll France

22, rue Albert Einstein

F-77420 CHAMPS-sur-MARNE

Téléphone: +33 164684536

E-Mail: info@ingersoll-imc.fr

Site web: www.ingersoll-imc.fr



www.ingersoll-imc.de

WINCUT